

INTRODUCTION TO WIRELESS COMMUNICATION SYSTEMS

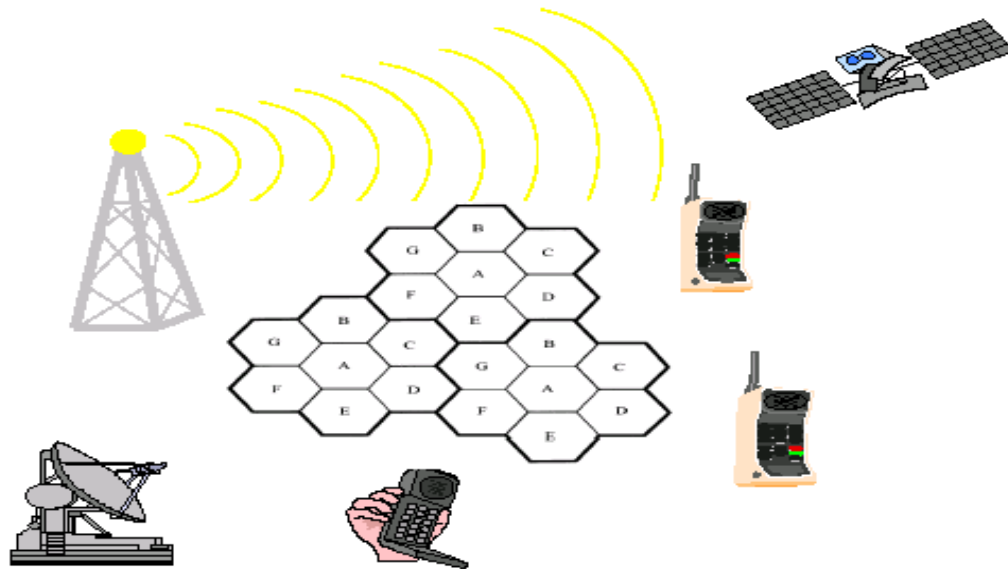

By

G.Jahnavi

Asst.Professor ECE Dept

Block diagram of Communication

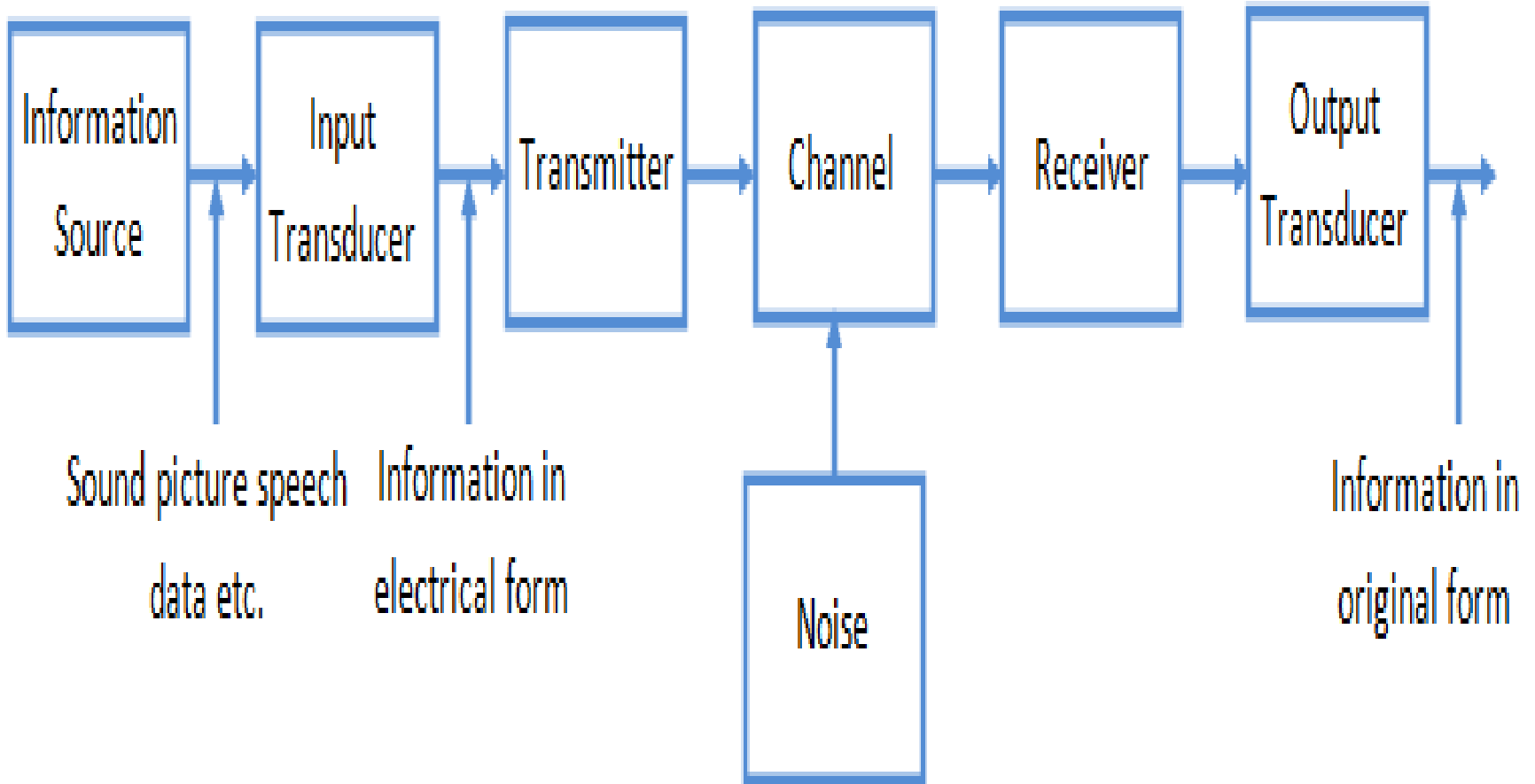

Evolution of Mobile Communications

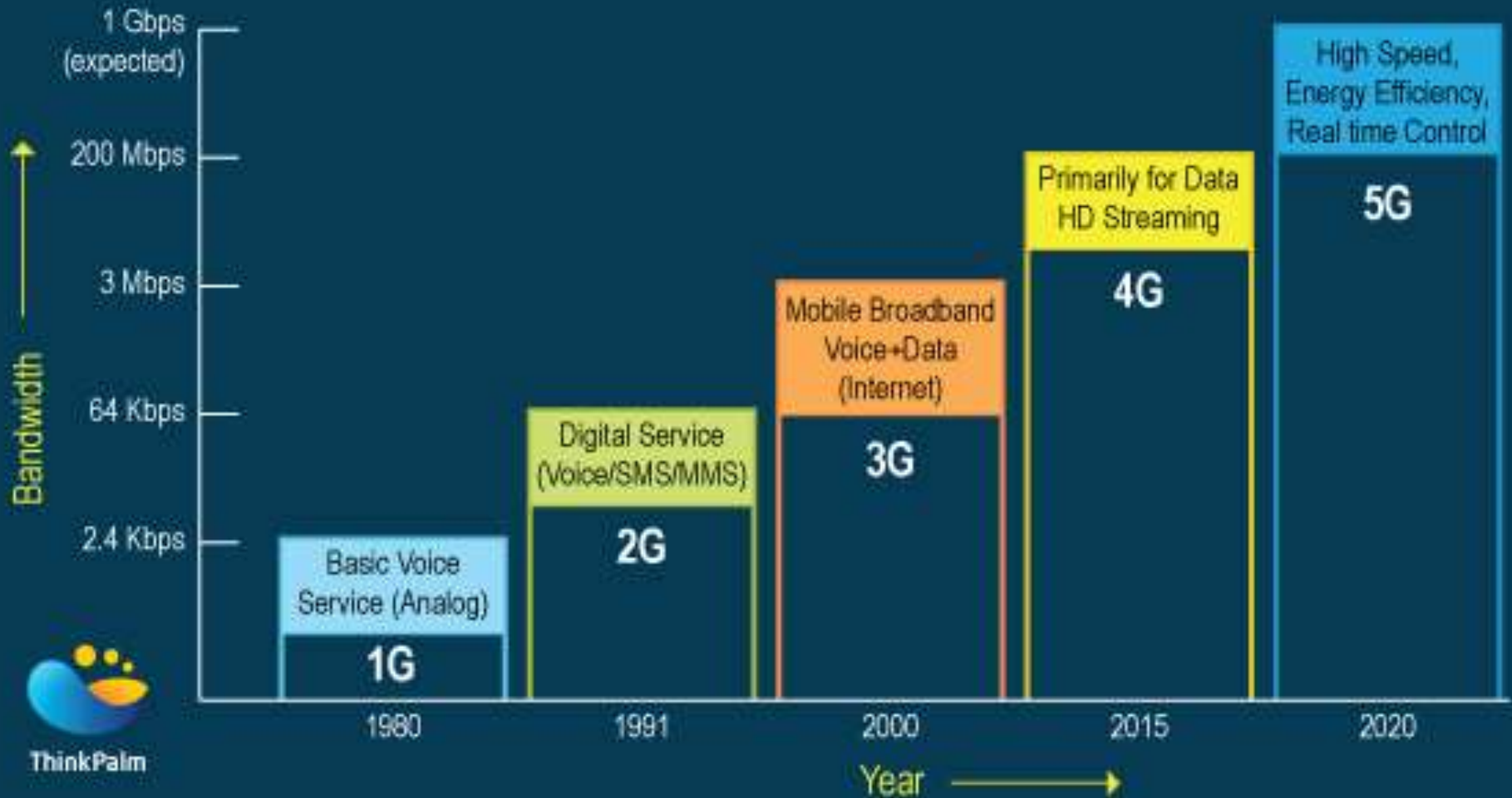

- **Classification of Mobile Transmission system**
 - **Simplex: communication in only one direction**
 - **Half-duplex: same radio channel for both transmission and reception (push-to-talk)**
 - **Full-duplex: simultaneous radio transmission and reception**

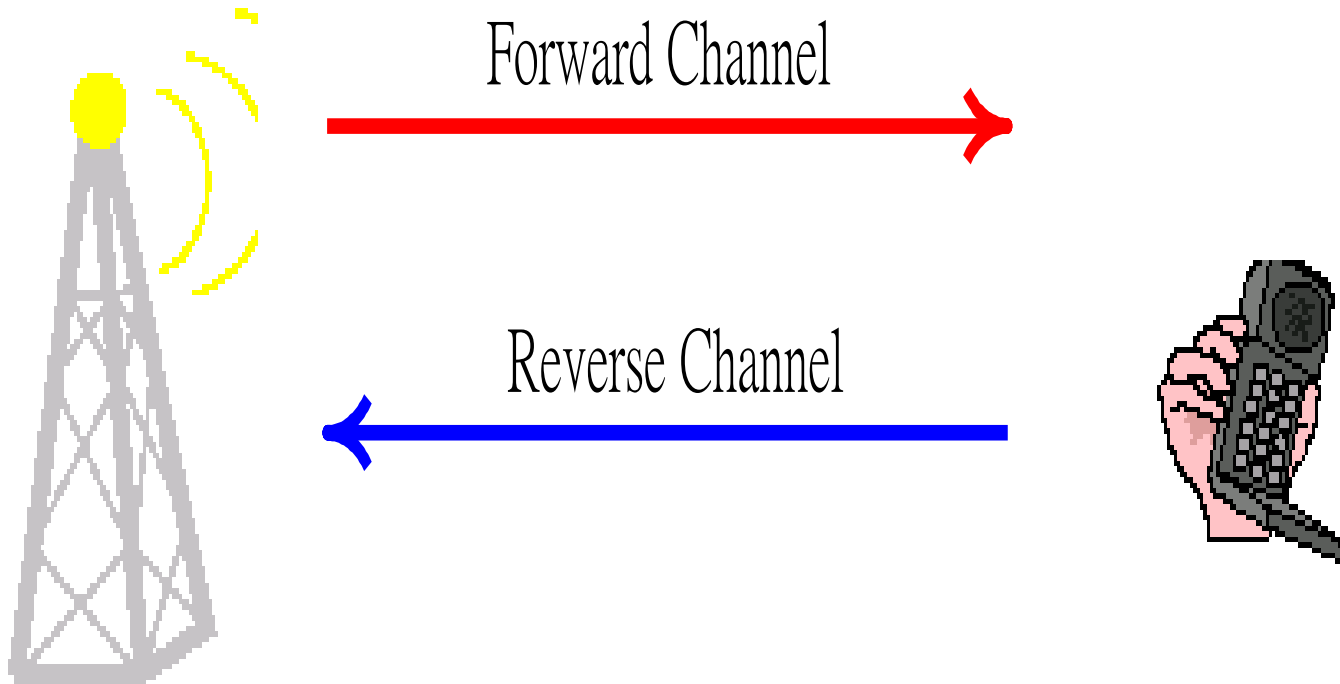

Cellular Mobile Systems

- Characteristics
 - Large number of users
 - Large Geographic area
 - Limited frequency spectrum
 - Reuse of the radio frequency by the concept of “cell”.
- Basic cellular system: Mobile stations, Base stations, and Mobile switching center.

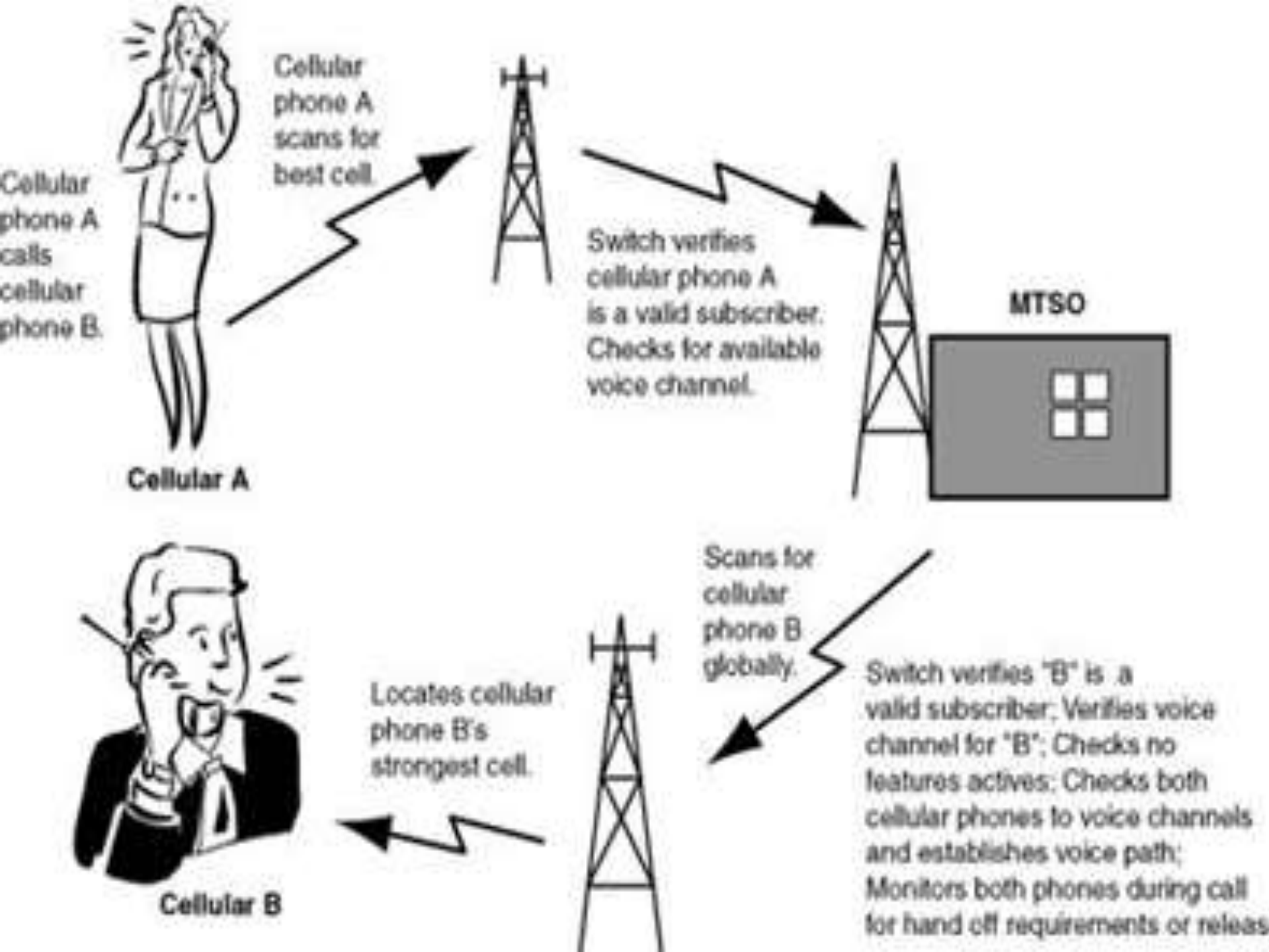



Thank
you!!